

Classic Range

## 2 Roll Cored Toilet Roll Dispenser



Product Code: 78417 (SS/WH)

### Product Description:

- Suitable for two 100m cored toilet rolls
- Ensures a spare roll is always available, which drops into place when required
- Inertia type brake mechanism helps to prevent the unnecessary wasting of paper
- Locking mechanism secures and protects the toilet rolls from pilfering



### Recommended installation height:

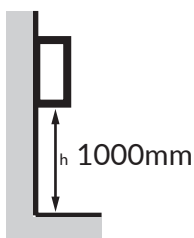

Available finishes:



Brushed  
Stainless Steel



White

<b>Material:</b>	Stainless Steel / Powder Coated Steel
<b>Dimensions:</b>	W.135mm x H.272mm x D.159mm
<b>Weight:</b>	1.8kg
<b>Packing/Carton:</b>	1 piece
<b>Finish:</b>	Brushed / White Powder Coated

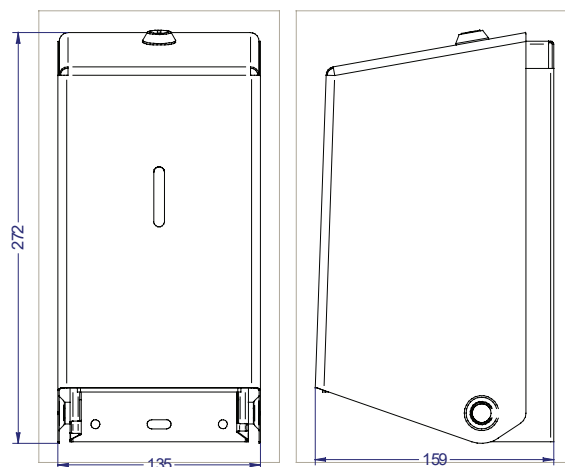

**Dudley Industries Ltd**  
Preston Road, Lytham St Annes, Lancashire. FY8 5AT



**Tel:** +44 (0) 1253 738311  
**Email:** sales@dudleyindustries.com  
**Web:** www.dudleyindustries.com