

## Technical Data Sheet

### Classic Behind the Mirror Range Pull Down Soap Dispenser 2L

---

Applicable to products:

92071SS     Classic Behind the Mirror Pull Down 2L Soap Dispenser Battery Powered

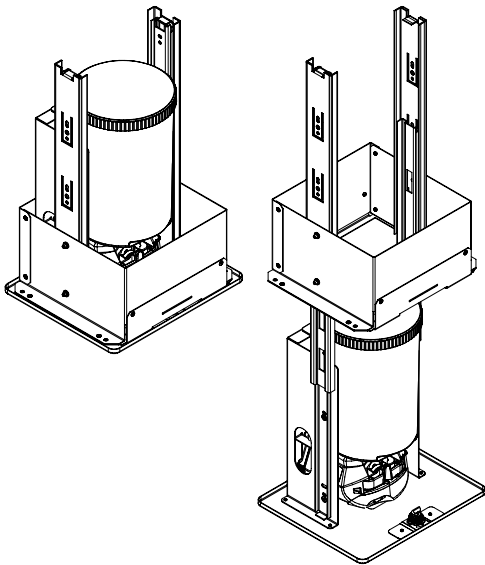

**Innovative touch-free soap dispenser with large capacity, for discrete installation behind a mirror in bespoke cabinets.**

Product Image:

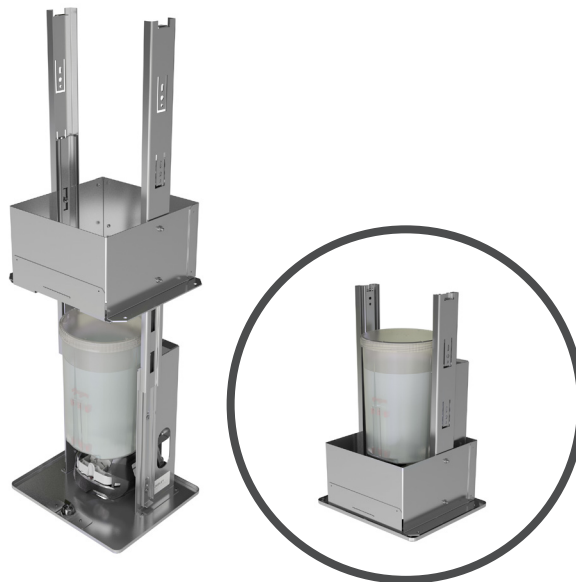

Product Description:

- Large 2L capacity touch free soap dispenser ideal for busy washrooms
- Holds enough soap for 3,200 dispenses
- Reservoir pulls down from the base of the cabinet for quick and easy to refilling
- Dispensing pump is compatible with liquid soap formulations
- Battery powered unit uses 4 x C Cell Batteries
- Base securely locks into position to secure the consumables
- Co-ordinating Paper Towel Dispenser also available
- Manufactured from hygienic stainless steel with plastic reservoir

Installation options:

- Suitable for installation into bespoke cabinetry, full installation guidelines are available separately
- The dispenser is fixed into place using 4 base panel fixings

# Technical Data Sheet

## Classic Behind the Mirror Pull Down 2L Soap Dispenser 92071SS Battery Powered



### Product Specification:

<b>Material:</b>	Stainless Steel + mixed material components
<b>Dimensions:</b>	Closed: W.228mm x H.353mm x D.195mm Base panel depth below unit: 8mm Pull Down allowance needed below unit: 358mm
<b>Finish:</b>	Natural Stainless Steel
<b>Packing/Carton:</b>	1 piece
<b>Warranty:</b>	10 years

### Line Drawing:

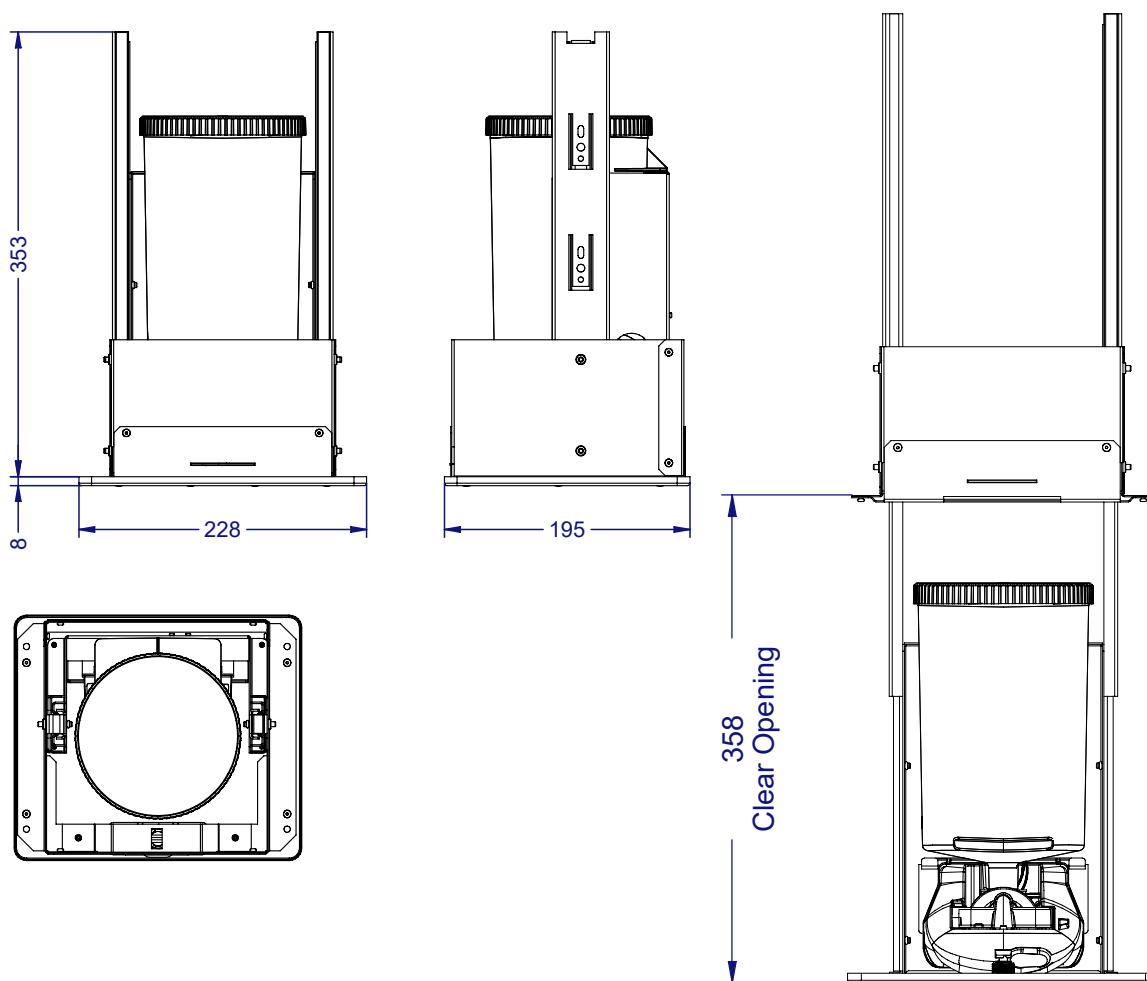

Dudley Industries Ltd  
Preston Road, Lytham St Annes, Lancashire. FY8 5AT



Tel: +44 (0) 1253 738311  
Email: sales@dudleyindustries.com  
Web: www.dudleyindustries.com