

## Technical Data Sheet

### Platinum Range 1L Foam Soap Dispenser

---

Applicable to products:

- 50014CB Platinum 1L Foam Soap Dispenser Cartridge Fill
- 50015CB Platinum 1L Foam Soap Dispenser Bulk Fill

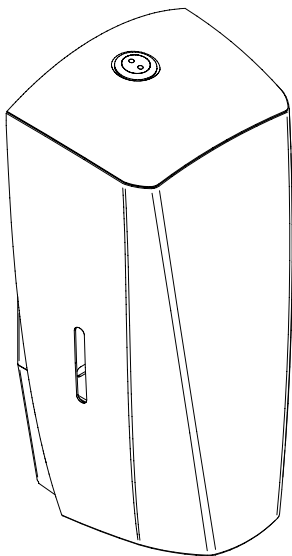

**Platinum 1L Foam Soap Dispenser**

50014CB Cartridge Fill

50015CB Bulk Fill

---

**Platinum 1L Soap Dispenser where style meets functionality, elevating your washroom experience with its sleek design and efficient operation.**

Product Image:



**Product Description:**

- Compact design for 1L foam soap, dispenses a generous 1,600 shots of foam soap.
- Choose from cartridge refill or bulk fill options.
- Easily operated by one hand pushing the cover to dispense the foam soap into the hand.
- Recessed two-pin, locking mechanism secures and protects refill from pilfering.
- Easy to unlock and the cover hinges forward for ease of refilling.
- Cover simply snap locks into place when closing.
- Innovative coating helps prevent fingerprint marks to keep dispensers looking their best.
- Easy to wipe clean.
- Viewing windows allow for easy consumable level check.

**Soap Cartridge Refill:**

50082NF - Foam Soap Cartridge - Natural Fresh (6 x 1000ml)

**Available Finishes:**

Brushed with clear lacquer

Available for specification at:

# Technical Data Sheet

## Platinum 1L Foam Soap Dispenser

50014CB Cartridge Fill

50015CB Bulk Fill



### Product Specification:

<b>Material:</b>	Stainless Steel
<b>Dimensions:</b>	W.120mm x H.250mm x D.102mm
<b>Finish:</b>	Brushed with clear lacquer
<b>Weight:</b>	1kg
<b>Warranty:</b>	10 years

### General Assembly:

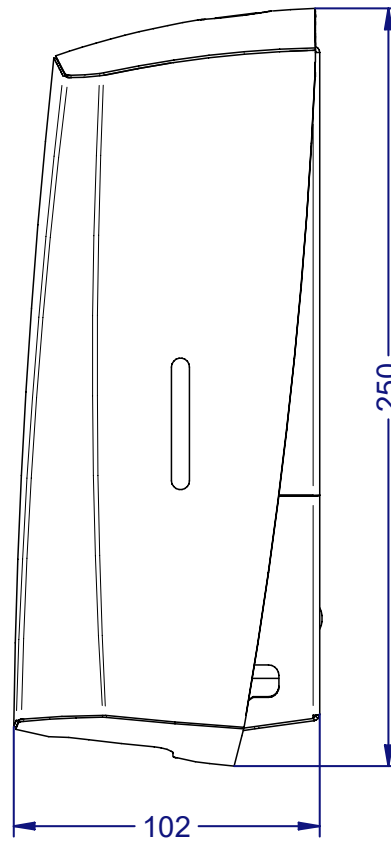
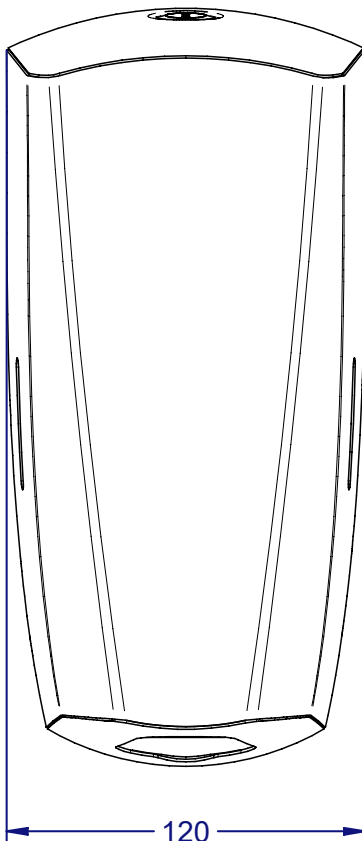
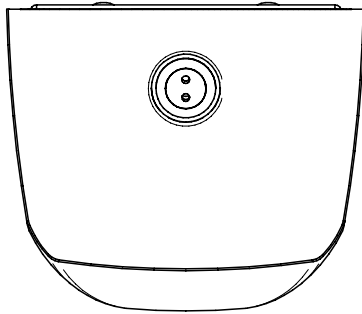

**Platinum 1L Foam Soap Dispenser**

50014CB Cartridge Fill

50015CB Bulk Fill

Fixing Holes:

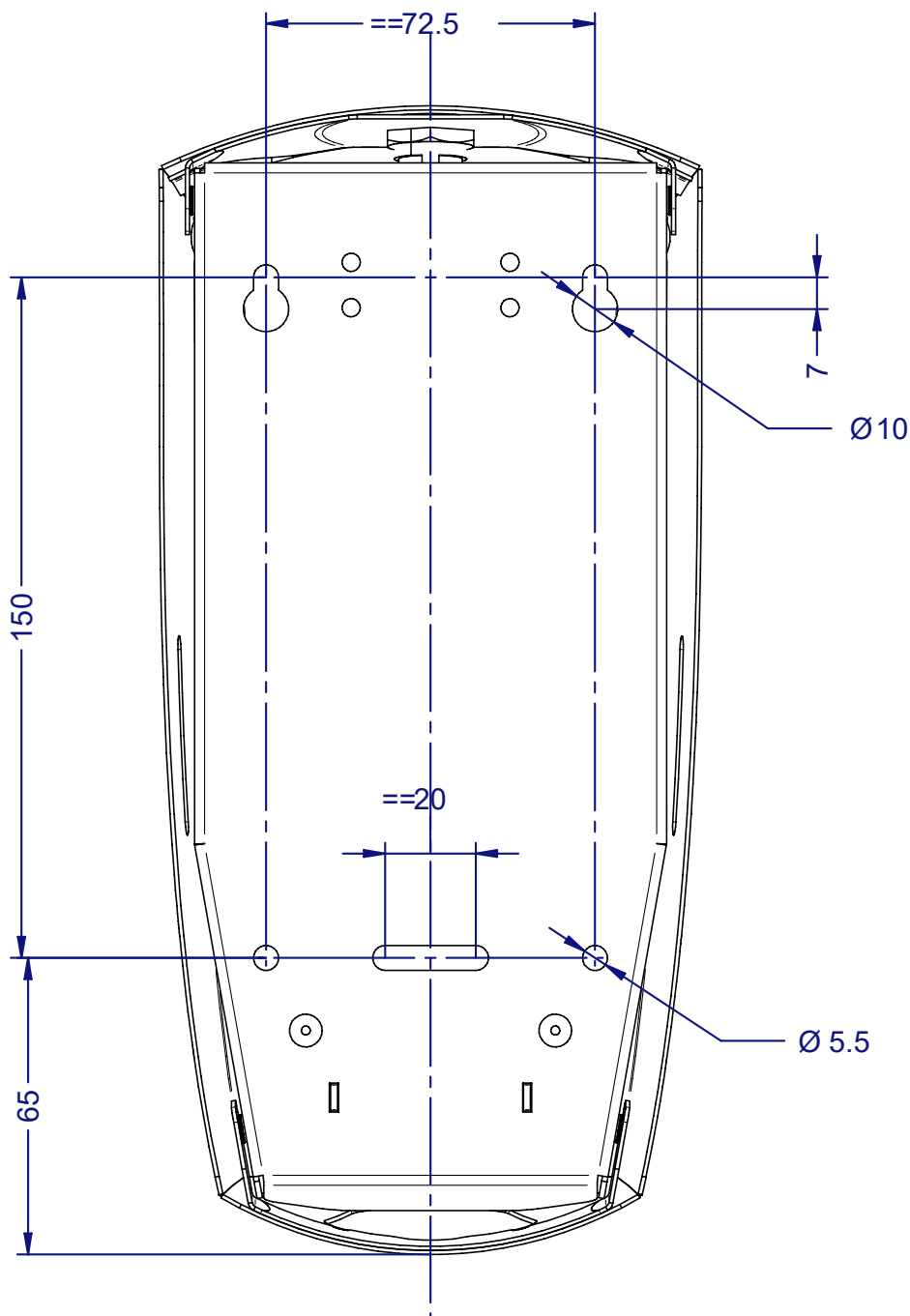

Dudley Industries Ltd  
Preston Road, Lytham St Annes, Lancashire. FY8 5AT

Tel: +44 (0) 1253 738311  
Email: sales@dudleyindustries.com  
Web: www.dudleyindustries.com

