

## Technical Data Sheet

### Platinum Range Air Freshener

---

Applicable to products:

51650CB Platinum Air Freshener

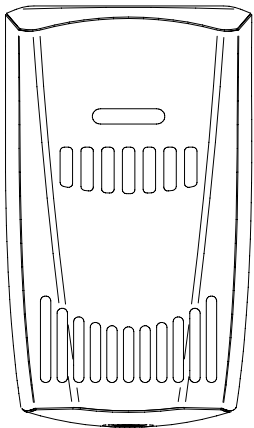

---

Gel formulation provides continuous, gentle and quiet fragrance delivery throughout the washroom.

Product Image:



Product Description:

- Battery operated for ease of installation with long lasting battery life.
- Compact design makes it suitable for all types of washroom environments.
- Robust and tamper-proof.
- Innovative coating helps prevent fingerprint marks to keep dispensers looking their best.
- Easy to wipe clean.

**Gel Fragrance Refills:**

**FC0127** Cotton Breeze (30 x 100ml)

**FC0123** English Lavender (30 x 100ml)

**Available Finishes:**

Brushed with clear lacquer

# Technical Data Sheet

## Platinum Air Freshener 51650CB



### Product Specification:

<b>Material:</b>	Stainless Steel
<b>Dimensions:</b>	W.118mm x H.219mm x D.91mm
<b>Weight:</b>	0.9kg
<b>Finish:</b>	Brushed with Clear Lacquer

### General Assembly:

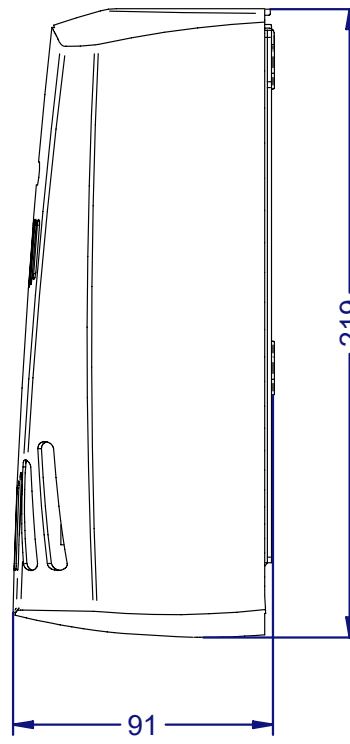
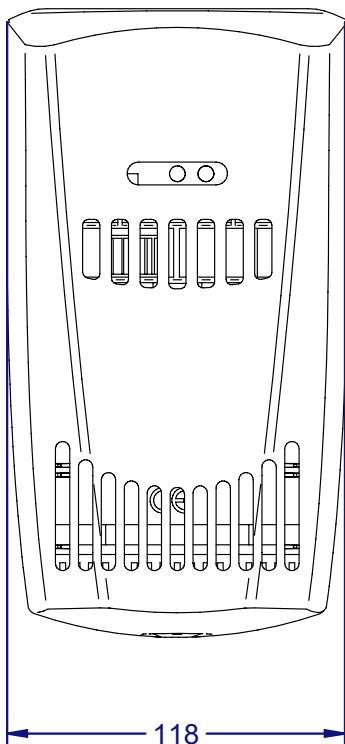
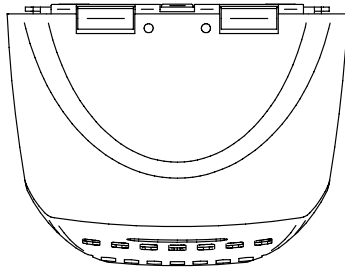

Fixing Holes:

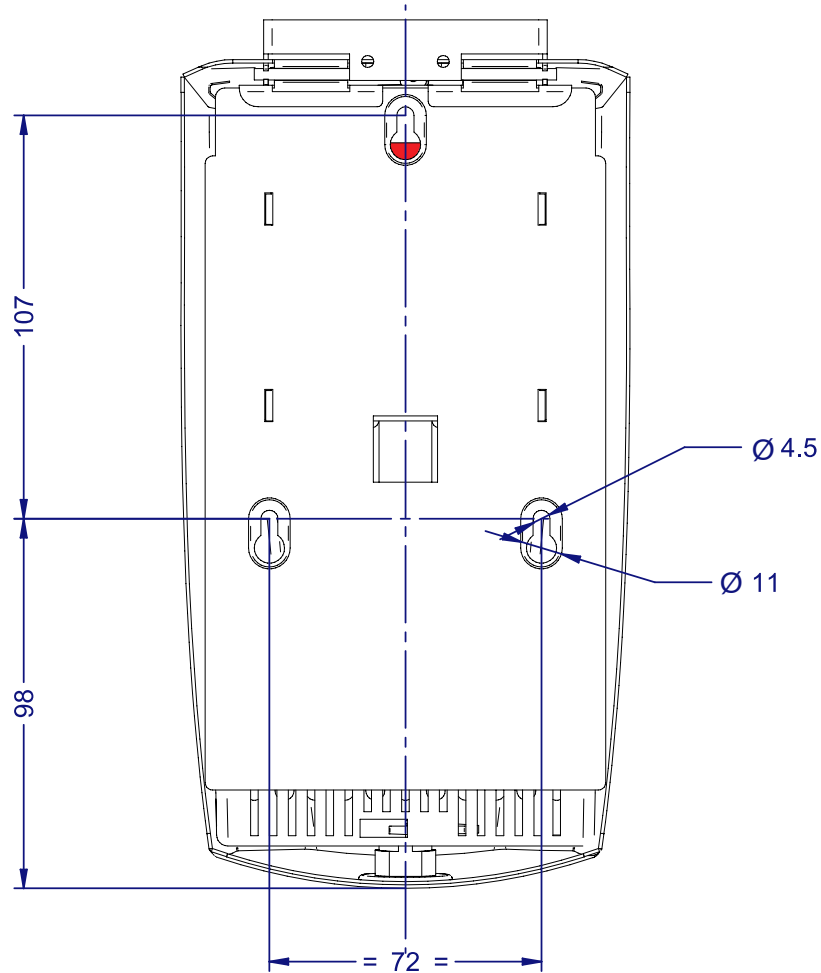

Recommended installation height:

From Floor: 250cm

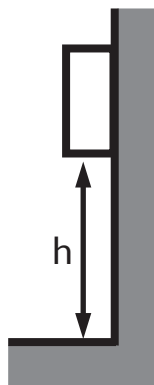

Dudley Industries Ltd  
Preston Road, Lytham St Annes, Lancashire. FY8 5AT